

INSTRUCTIONS AND ADVICE FOR THE USE, INSTALLATION AND MAINTENANCE OF BUILT-IN ELECTRIC HOBS

Downloaded from www.vandenborre.be

Dear Customer,

Thank you for having purchased one of our products.

We are certain that this new, modern, functional and practical appliance, built with the very highest quality materials, will meet your requirements in the best possible way. This hob is easy to use. It is, however, important to thoroughly read the instructions in this handbook in order to obtain the best results.

The manufacturer shall not be held responsible for any damages to persons or property caused by incorrect installation or use of the appliance.

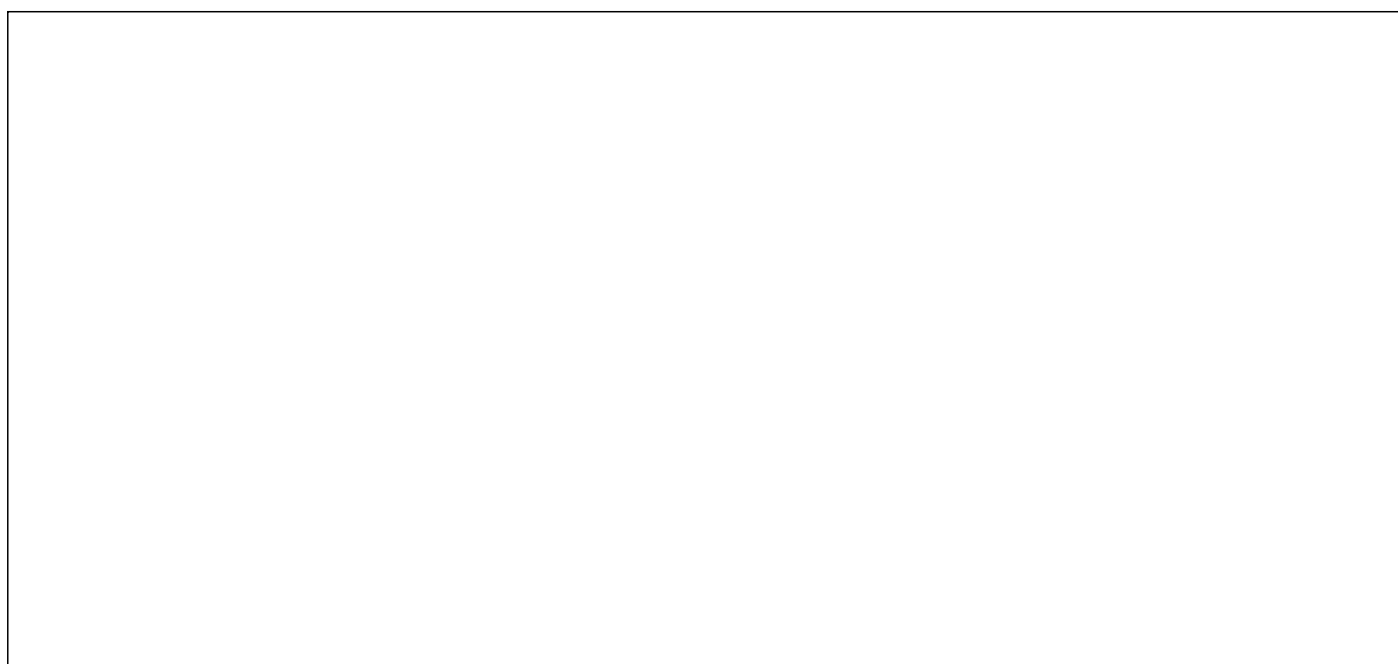

TIPO: PAZ04
MOD.: SE435S

SMEG S.p.A.
Via Leonardo da Vinci, 4
42016 GUASTALLA - ITALIA

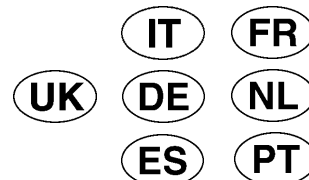

The Manufacturer shall not be held responsible for any inaccuracies in this handbook due to printing or transcription errors; the designs in the figures are purely indicative. The Manufacturer also reserves the right to make any modifications to the products as may be considered necessary or useful, also in the interests of the user, without jeopardizing the main functional and safety features of the products themselves. ***This cook top was designed to be used exclusively as a cooking appliance: any other use (such as heating rooms) is to be considered improper and dangerous.***

WARNING: the appliance and its accessible parts become hot during use.

Care should be taken to avoid touching heating elements. Children less than 8 years of age shall be kept away unless continuously supervised.

This appliance can be used by children aged from 8 years and above and persons with reduced physical, sensory or mental capabilities or lack of experience and knowledge if they have been given supervision or instruction concerning use of the appliance in a safe way and understand the hazards involved.

Children shall not play with the appliance.

Cleaning and user maintenance shall not be made by children without supervision.

WARNING: unattended cooking on a hob with fat or oil can be dangerous and may result in fire. NEVER try to extinguish a fire with water, but switch off the appliance and then cover flame e.g. with a lid or a fire blanket.

WARNING: danger of fire: do not store items on the cooking surfaces.

The instructions regarding the **stove, hobs** and **ovens** must indicate that you should not use an appliance for steam cleaning.

The instructions for **hobs** shall state that the appliance is not intended to be operated by means of an external timer or separate remote-control system.

DESCRIPTION OF THE HOT PLATES

TYPE: PAZ04

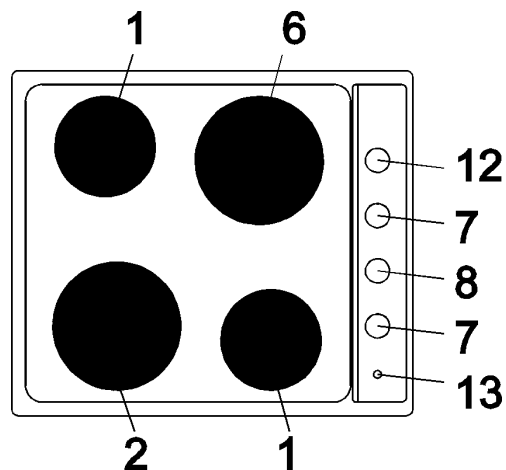
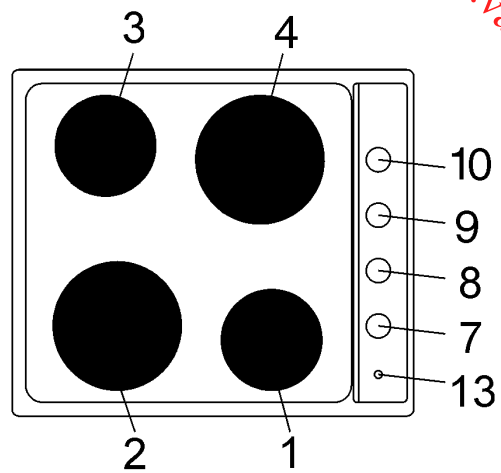
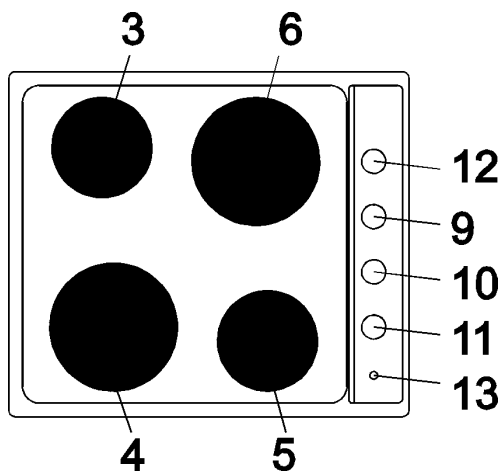

- | | |
|---|--------|
| 1 Normal plate Ø 145 of | 1000 W |
| 2 Normal plate Ø 180 of | 1500 W |
| 3 Rapid plate Ø 145 of | 1500 W |
| 4 Rapid plate Ø 180 of | 2000 W |
| 5 Thermostat plate Ø 145 of | 1500 W |
| 6 Thermostat plate Ø 180 of | 2000 W |
| 7 Control knob for electric plate n° 1 | |
| 8 Control knob for electric plate n° 2 | |
| 9 Control knob for electric plate n° 3 | |
| 10 Control knob for electric plate n° 4 | |
| 11 Control knob for electric plate n° 5 | |
| 12 Control knob for electric plate n° 6 | |
| 13 Warning light indicating that one or more plates are operating | |

USE

1) SWITCHING ON THE ELECTRIC PLATES

The hobs may be equipped with three types of electric plates: normal, thermostat and rapid plates indicated by a red mark. The normal plates and the rapid plates are controlled by a 7 - position switch (see fig. 1). The thermostat plates are controlled by 12 - position switch (see fig. 2).

Switch on the plates by turning the knob to the required position.

A diagram is screen-printed on the front panel. This

diagram indicates to which electric plate the knob in question corresponds (see fig. 1 - 2).

A red warning light will come on to indicate that the plate has been ignited.

2) HOW TO USE THE ELECTRIC PLATES

A purely indicative plate regulation chart is given below.

TABLE

NORMAL AND RAPID PLATE	THERMOSTAT PLATE	HEAT INTENSITY	POSSIBLE COOKING PROCESSES
0		Off	
1	1	Weak	To dissolve butter, chocolate, etc.. To heat small amounts of liquid.
2	1 - 4	Low	To heat larger amounts of liquid. To prepare cremes and suces requiring long slow cooking times.
3	4 - 8	Slow	To thaw frozen foods and prepare stews, heat to boiling point or simmer.
4	8 - 10	Medium	To heat foods to boiling point. To brown delicate meats and fish.
5	10 - 12	Strong	For escalopes and steaks. To simmer large amounts of food.
6	12	High	To bring large amounts of liquid to the boil. For frying.

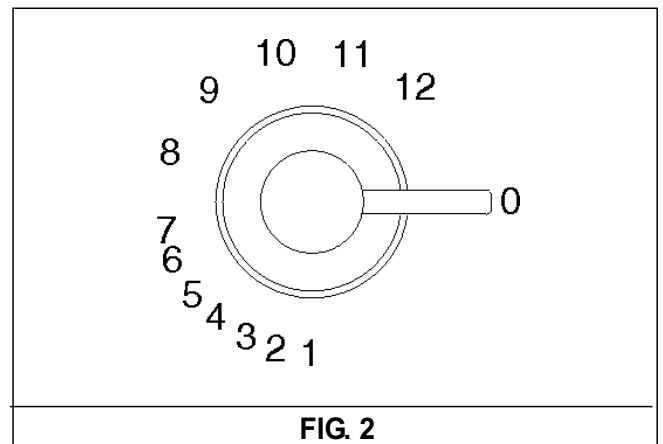
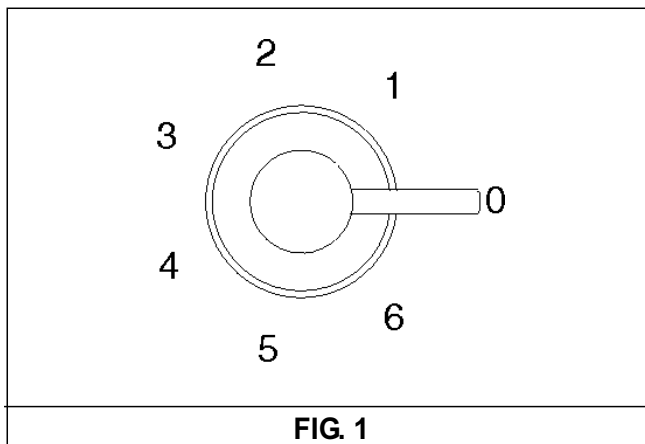

USE

WARNINGS:

when the plate is switched on for the first time, or if it has remained unused for a long period, it should be dried for 30 minutes on switch position n° 1. This will eliminate any moisture that may have been absorbed by the insulating material.

To correctly use the appliance, remember:

- to place a pan on the plate before switching this on.
- To always use pans with flat and very thick bottoms (see fig. 3).
- To never use pans that are smaller than the plate diameters.
- To dry the bottom of the pan before placing it on the plate.
- Correctly preserve the plate after use by treating it with special products, easily available on the market. This will keep the surface of the plate clean and bright. The operation will also prevent the formation of rust. Never allow children to play near the appliance when using the plates. Check that the pan handles are positioned correctly. The user should never leave the appliance unattended when cooking with easily inflammable oil and fat.
- The plates will remain hot for a long period of time even after use. Never touch them with the hands or other objects in order to prevent scorching.
- If the appliance has a glass lid, this could shatter when the cooker becomes hot. Always disconnect all the plates before closing the lid.
- Immediately disconnect the appliance from the electricity main as soon as cracks are noted on the surfaces of the plates.
- The machine must not be used by people

(including children) with impaired mental or physical capacities, or without experience of using electrical devices, unless supervised or instructed by an expert adult responsible for their care and safety. Children should not be allowed to play with the equipment.

- Containers wider than the unit are not recommended.
- The appliance must not be operated with an external timer or a separate remote-control system.
- Do not attempt to change the technical characteristics of the product because it can be dangerous.
- If you should not to use this appliance any more (or replace an old model), before disposing of it, make it inoperative in conformity with current law on the protection of health and the prevention of environmental pollution by making its dangerous parts harmless, especially for children who might play on an abandoned appliance.

WARNINGS AND ADVICE FOR THE USER:

- do not touch the appliance with wet or damp hands or feet.
- Do not use the appliance barefoot.
- The manufacturer will not be liable for any damage resulting from improper, incorrect or unreasonable use.
- During, and immediately after operation, some parts of the cook top are very hot: avoid touching them.
- After using the cook top, make sure that the knob is in the closed position.

Never cook food directly on the electric plates but always in a pot or container.

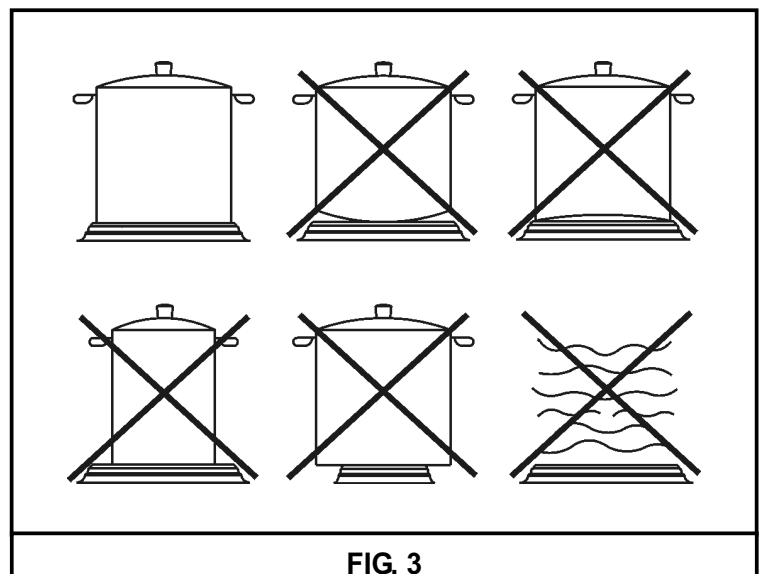

CLEANING

IMPORTANT:

always disconnect the appliance from the electricity main before carrying out any cleaning operation.

3) HOTPLATE

If you want to preserve the surface clean and bright, periodically wash the hot plate with lukewarm soapy water.

Following this, all parts should be thoroughly rinsed and dried. Never wash them while they are still warm and never use abrasive powders.

Do not allow vinegar, coffee, milk, salted water, lemon or tomato juice from remaining in contact with the enamelled surfaces for long periods of time.

WARNINGS:

- *correctly preserve the plate after use by treating it with special products, easily available on the market. This will keep the surface of the plate clean and bright. The operation will also prevent the formation of rust.*
- *Any liquid overflowed the pans, must be always remove with a rag.*
- *Don't use steam jets for the equipment cleaning.*
- *Burned food on an electric plate must be removed dry.*
- *After use, pour a little lukewarm oil on the plate and wipe it with a cloth.*

CORRECT USE OF THE ELECTRIC PLATES

When using the electric plates, you must:

- *absolutely not operate them empty (without a container);*
- *try not to pour liquids on the plates when they are hot;*
- *cook with a cover whenever possible to save electricity;*
- *an indicator light near the knob shows when the electric plates are turned on.*

INSTALLATION

Installation and maintenance must only be carried out by a qualified installer.

The appliance must be correctly installed in conformity with current law and the manufacturer's instructions.

Incorrect installation could cause damage to persons, animals and property for which the manufacturer cannot be held responsible.

4) INSTALLING THE HOT PLATE

Check that the appliance is in a good condition after having removed the outer packaging and internal wrappings from around the various loose parts. In case of doubt, do not use the appliance and contact qualified personnel.

Never leave the packaging materials (cardboard, bags, polystyrene foam, nails, etc.) within children's reach since they could become potential sources of danger.

The measurements of the opening made in the top of the modular cabinet and into which the hot plate will be installed are indicated in either fig. 4, comply with the measurements given for the hole into which the appliance will be recessed (see fig. 5).

If a wood is installed above the hob, please look at the hood manufacturer instructions regarding the minimum distance between hood and hob (fig. 5).

5) FIXING THE HOT PLATE

The hob has a special seal which prevents liquids from infiltrating into the cabinet. Strictly comply with the following instructions in order to correctly apply this seal:

- detach the seals from their backing, checking that the transparent protection still adheres to the seal itself.

- Overturn the hob and correctly position seal "E" (fig. 6) under the edge of the hob itself, so that the outer part of the seal itself perfectly matches the outer perimetral edge of the hob. The ends of the strips must fit together without overlapping.
- Evenly and securely fix the seal to the hob, pressing it in place with the fingers.
- Remove the strip of protective paper from the seal "F" fit the hooks into their relative housings "K" in the unit and set the hob into the hole in the cabinet. Lock it in place with the relative fixing screws "F" (see fig. 7).

WARNINGS:

be aware that the glue that join the laminated plastic to the furniture, has to resist to temperature not below 150 °C, to avoid the unstuck of the panelling.

The rear wall, adjacent and surrounding surfaces must therefore be able to withstand an temperature of 90 °C.

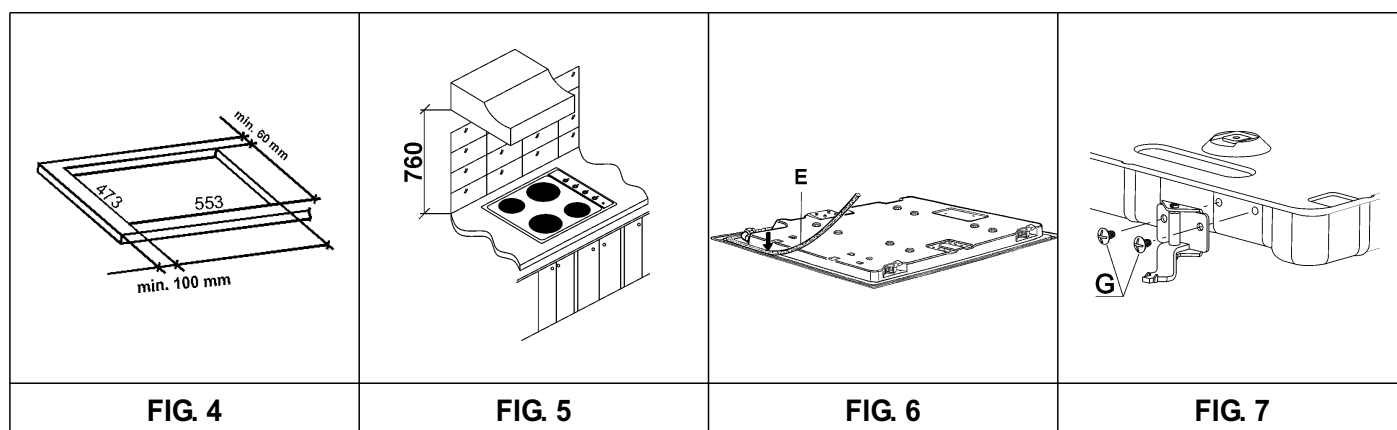

INSTALLATION

6) ELECTRICAL CONNECTIONS

IMPORTANT: the appliance must be installed following the manufacturer's instructions. The manufacturer will not be liable for injury to persons or animals or property damage caused by an incorrect installation.

Electrical connection must be carried out in compliance with the specifications and provisions in force.

Before proceeding with the connections, check that:

- the voltage matches the value shown on the specification plate and the section of the wires of the electrical system can support the load, which is also indicated on the specification plate.
- The voltage rating of the appliance and the current sockets suits the maximum power draw of the appliance (see data label affixed to the lower part of the appliance itself).
- The system is equipped with an efficient earth connection in compliance with the pertinent provisions in force. The manufacturer declines all responsibility for failure to comply with these provisions.
- If the appliance has no power cable, connect a cable of adequate section to the terminal strip (consult the table on next page) complying with the wiring diagram of fig. 8. This diagram is also affixed to the hot plate.

When connection to the electricity main is made by using a socket (gas version only):

- fit a standard plug to power cable (if supplied). This plug should be able to bear the load indicated on the data label. Connect the wires according to the diagram in fig. 8, remembering to comply with the following instructions:

Letter L (live) = brown wire;

Letter N (neutral) = blue wire;

Earth symbol \oplus = yellow-green wire.

- The powering cable must be positioned so that it is never able to reach an temperature of 90 °C in any part.
- Never use reductions, adapters or shunts for the connection since these could cause false contacts and dangerous overheating.
- The outlet must be accessible after the built-in.

When the appliance is connected straight to the electricity main:

- install an omnipolar cutout between the appliance itself and the main. This circuit-breaker should be sized according to the rating of the appliance and the opening between its contacts should be at least 3 mm.
- Remember that the earth wire must not be cut out by the switch.
- The electrical connection may also be protected by a high sensitivity differential switch.

Installers are strongly advised to connect the yellow- green earthing wire to an efficient earthing system.

The manufacturer cannot be responsible for the missing earthing of the appliance.

Before performing any service on the electrical part of the appliance, it must absolutely be disconnected from the electrical network.

If the installation requires modifications to the home's electrical system or if the socket is incompatible with the appliance's plug, have changes or replacements performed by professionally-qualified person. In particular, this person must also make sure that the section of the wires of the socket is suitable for the power absorbed by the appliance.

WARNINGS:

all our appliances are designed and manufactured in compliance with European standards EN 60 335-1 and EN 60 335-2-6 plus the relative amendments.

The appliance complies with the provisions of the following EEC Directives:

- CEE 2004/108/CE regarding to electromagnetic compatibility.
- CEE 2006/95 regarding electrical safety.

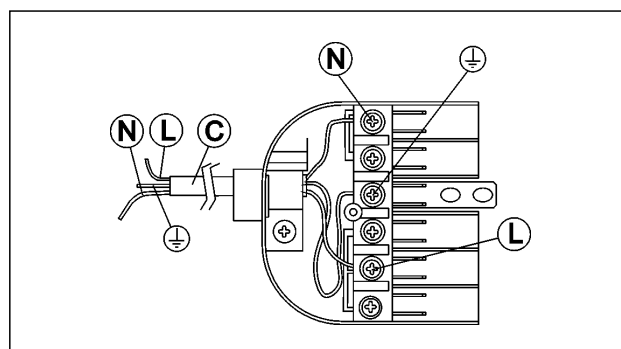

FIG. 8

CONVERSIONS

Disconnect the appliance from the mains supply prior to any conversions being carried out.

7) CHANGING THE TYPE OF POWER SUPPLY

Although they leave our factory preset for single-phase connection, certain appliances may be converted to the three-phase system.

Comply with the following instructions:

a) remove the hotplate from the top of the cabinet, overturn it, unscrew screw "Z" and remove under part (see fig. 9).

b) Shift connecting plate on terminal according to the following chart. This chart is also affixed to the hob.

c) Insert a supply cable of adequate section (see chart par. 10) through core hitch on the terminal board.

d) Connect the phase and earth wires to the relative terminal board.

e) Fix the supply cable in place using clamp.

f) Refit the hotplate, complying with the above instructions in reverse.

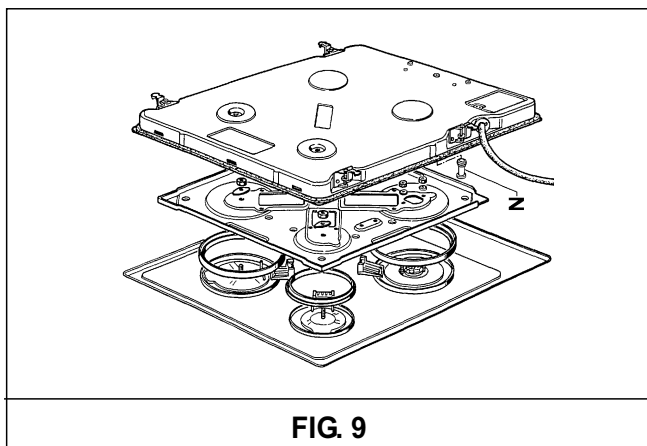

FIG. 9

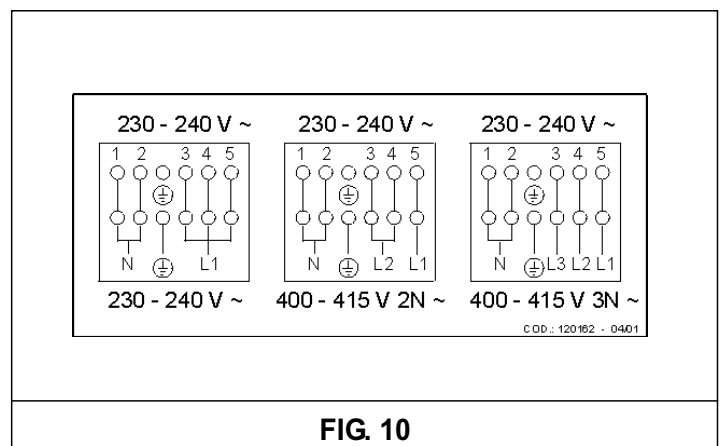

FIG. 10

SERVICING

Always disconnect the appliance from the electricity main before proceeding with any servicing operation.

8) REPLACING THE ELECTRICAL COMPONENTS

For access to the various parts, remove the hotplate from the top of the cabinet. Then overturn it, unscrew screw "Z" and remove under part. (see fig. 9).

After these actions is possible to work on the plates, commutators, clamps and input cable.

N.B. In case of substitution of the input cable, the installer must keep the "earth" conductor longer than "live" ones, and must respect the cautions in paragraph "Electrical connection".

To reassemble the appliance repeat the inverse process.

9) TECHNICAL CHARACTERISTICS OF THE ELECTRICAL COMPONENTS

To facilitate the job of the installer we present a scheme with the characteristics of the components.

POWER OF ELECTRICAL COMPONENTS DENOMINATIONS W

Denominations	W
Normal plate Ø 145 mm – 7 positions with the protector	1000
Normal plate Ø 180 mm – 7 positions with the protector	1500
Rapid plate Ø 145 mm – 7 positions	1500
Rapid plate Ø 180 mm – 7 positions	2000
Thermostat plate Ø 145 mm – 12 positions	1500
Thermostat plate Ø 180 mm – 12 positions	2000

TYPE AND SECTION OF THE POWER CABLES

Cable type	Single phase power 230 - 240 V~	Three phase power 400 V 3N ~ 400 - 415 V 3N~	Three phase power 400 - 415 V 2N~
Rubber H05 RR-F	3 X 2.5 mm ² (*)	5 X 1.5 mm ² (*)	4 X 1.5 mm ² (*)
Polycropropene H05 RN-F	3 X 2.5 mm ² (*)		

(*) keeping in mind the contemporaneousness factor

TECHNICAL DATA

Downloaded from www.yandenborre.be

MODEL WITH 2 RAPID PLATES + 2 THERMOSTAT PLATES

VOLTAGE	230 - 240 V~
FREQUENCY	50/60 Hz
TOT. RATING	7000 W

MODEL WITH 2 RAPID PLATES + 2 NORMAL PLATES (with protector)

VOLTAGE	230 - 240 V~
FREQUENCY	50/60 Hz
TOT. RATING	6000 W

MODEL WITH 3 NORMAL PLATES (with protector) + 1 THERMOSTAT PLATE

VOLTAGE	230 - 240 V~
FREQUENCY	50/60 Hz
TOT. RATING	5500 W

**WARNING: MAINTENANCE MUST ONLY BE
PERFORMED BY AUTHORIZED PERSONS.**

TECHNICAL ASSISTANCE AND SPARE PARTS

This appliance, before leaving the factory, has been carefully tested and regulated by expert and specialized personnel in order to guarantee the best performances.

Any repairs or adjustments which may be subsequently required may only be carried out by qualified personnel with the utmost care and attention.

For this reason, always contact your Dealer or your nearest After Sales Centre whenever repairs or adjustments are required, specifying the type of fault and the model of appliance in your possession.

Please also note that genuine spare parts are only available from our After Sales Service Centres and authorized retail outlets.

The above data are printed on the data label put on the inferior part of the appliance and on the packing label.

The above informations give to the technical assistant the possibility to get fit spare parts and a heaven-sent intervention. We suggest to fill the table below.

MARK:

MODEL:

SERIES:

This appliance is marked according to the European directive 2002/96/EC on Waste Electrical and Electronic Equipment (WEEE).

This guideline is the frame of a European-wide validity of return and recycling on Waste Electrical and Electronic Equipment.

